

Description:

A wide range of pipe diameters starting from 48 to 692 mm.

Ideal for connecting rigid pipes of different materials such as PVC, asbestos cement, ductile iron, steel, etc...

Technical specifications:

OPERATING PRESSURE: NP 16

Surface : blue epoxy powder 250 μ

Ductile iron: GGG-50

Conform to the Standard: EN 545



N°	DESIGNATION	MATERIALS
1	Body	Ductile iron GGG-50
2	End ring	Ductile iron GGG-50
3	Screw and nut	Galvanized carbon steel
4	Ring	EPSM/NBR

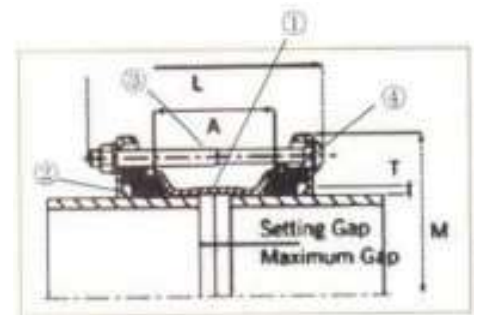



LARGE TOLERANCE ADAPTER (MAXIFIT)

Dimensions:

Size (mm)	Size range (mm)		DIAM (mm)	length (mm)
	MIN	MAX	M	L
ND40	48.0	60.0	149.5	190.0
ND 50	59.0	72.0	154.5	190.0
ND 60	68.0	85.0	173.5	190.0
ND 80	84.0	106.0	195.5	190.0
ND 100	109.0	130.0	224.5	190.0
ND 125	132.0	159.0	254.5	190.0
ND 150	157.0	183.0	280.5	190.0
ND 175	192.0	210.0	306.5	230.0
ND 200	218.0	242.0	342.5	230.0
ND 225	242.0	269.0	367.5	230.0
ND 250	244.0	276.0	399.5	230.0
ND 250-A	266.0	297.0	462.5	230.0
ND 300	314.0	356.0	462.5	230.0
ND 300-A	315.0	335.0	462.5	230.0
ND 300-B	334.0	355.0	466.0	242.0
ND 250-A	374.0	391.0	489.0	242.0
ND 400	386.0	410.0	521.0	292.0
ND 400-A	410.0	436.0	534.0	292.0
ND 500	500.0	532.0	628.0	292.0
ND 500-A	527.0	544.0	640.0	292.0
ND 500-B	555.0	572.0	668.0	292.0
ND 500-C	566.0	583.0	679.0	292.0
ND 500-D	582.0	599.0	695.0	292.0
ND 600	600.0	630.0	726.0	292.0
ND 600-A	630.0	647.0	743.0	292.0
ND 600-B	645.0	662.0	758.0	292.0
ND 600-C	662.0	679.0	775.0	292.0
ND 600-D	675.0	692.0	788.0	292.0

ALMA - MANUFACTURE MAROCAINE D'EQUIPEMENTS PUBLICS - MMEP - S.A.

ZI, Had soualem, Douar LAASILAT, Commune de sahel, Ouled Hriz-Cercle de Berrechid-26400 Maroc

Tél.: +212 5 22 99 51 52

- Fax : +212 5 22 99 49 50

Email : contact@alma.ma - **siteweb :** www.alma.ma

Certifié par
BUREAU VERITAS
Certification

