

PN 16
Connection DN 100
Closure with operating square
Compliant with current standard EN 14384
Total sealing
Low operating torque
Automatic Drain
Coating:
blue Epoxy interior and exterior paint for the buried parts
Red polyester paint for visible parts

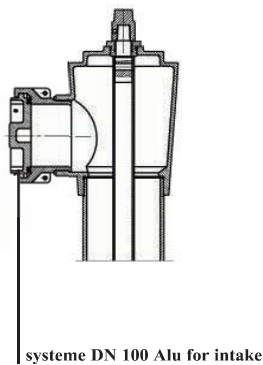
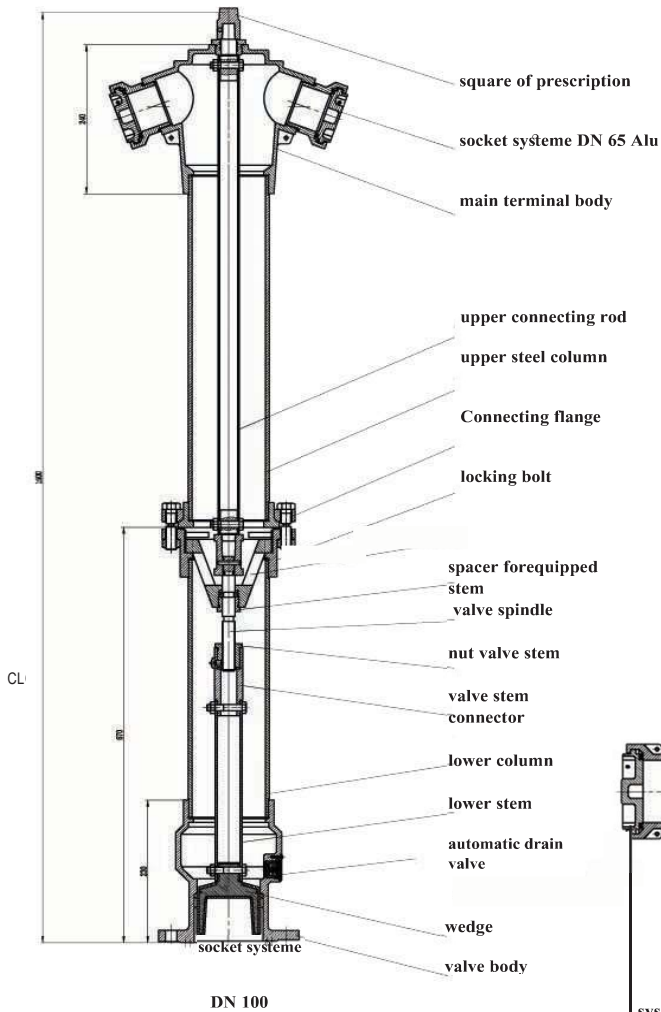

EN 14384
 NOTIFIED BODY N°: 0409

FIRE HYDRANT
DUCTILE IRON
GGG40

PN16 - CONNECTION DN 100
 CLOSING WITH OPERATING SQUARE

water intakes	Nb
output DN 65 mm	2
output DN 100mm	1



Delivered with Duckfoot Bend

